

Analog-3D-Probe

- High precision and linearity – suitable for measurement
- Simple to calibrate
- Excellent readability due to measuring range spread
- One scale for radial and axial measurement
- Comfortable and simple concentricity adjustment
- Large measuring range in all directions
- Impact protected and water proof (IP 67)
- Compact metal housing and long probe arm
- Screwable stylus

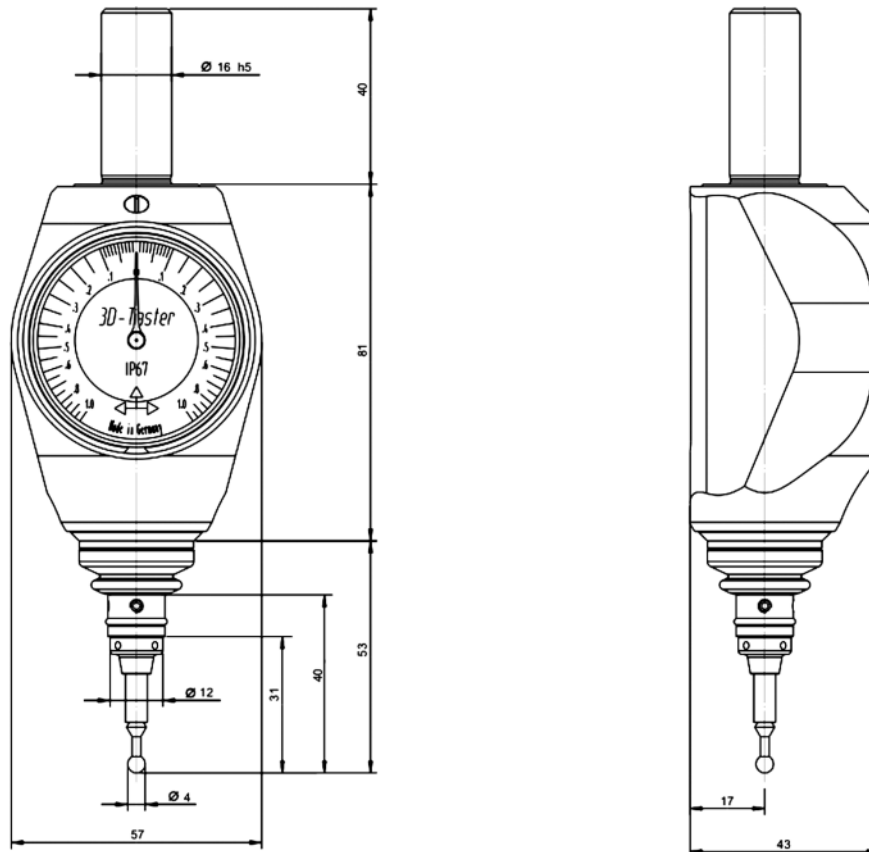

Shank diameter	16 mm
Measuring accuracy	0.01 mm
max. deflection x, y, z, each	6.6 mm
Dimensions l, w, d	174 mm, 57 mm, 43 mm
Free length of stylus	40 mm
Concentricity adjustment range	+/-0.5 mm
Weight	397 g



Accessories

Stylus

Stylus	Ø 4 mm
Length	31 mm

